



AUDI AG  
85045 Ingolstadt  
www.audi.com  
Valid from March 2011

Printed in Germany  
133/1131.89.18

The models and equipment versions illustrated and described in this brochure and some of the services listed are not available in all countries. Some of the cars illustrated are equipped with optional equipment for which an extra charge is made. Details concerning the delivery specifications, appearance, performance, dimensions and weights, fuel consumption and running costs of the vehicle were correct to the best of our knowledge at the time of going to press. Deviations from the colours and shapes shown in the illustrations may occur. No liability is accepted for errors and printing errors. The right to introduce modifications is reserved. Not to be reproduced, including in part, without the written approval of AUDI AG.

This brochure is printed on paper made from pulp bleached without the use of chlorine.

Audi A8 L Security

# A8

Audi A8 L Security

Vorsprung durch Technik 





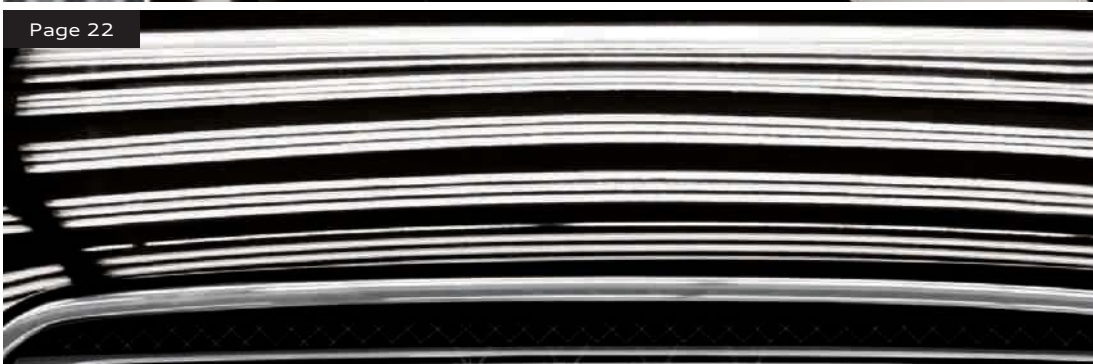

	Page
Fascination	
	6 Design
	12 Interior
	16 Audi Space Frame (ASF)
	18 Manufacture
	20 Armouring and protective functions
	28 Firing test
	32 Drive
	34 Driver assistance systems
	36 Audi Security Training/Audi Security Service
Equipment	
	40 Equipment
	43 Technical data
	44 Dimensions

---

## Progress in Security.

Those who move in the highest circles every day need a limousine that doesn't only play safe. They need one that redefines security. The Audi A8 L Security combines the high protection level of resistance class VR7 (according to BRV 2009) with unique safety features to produce a superior all-round safety package. Giving you the certain knowledge that you can cope with critical situations safely – or quickly avoid them in the ideal case. And allowing you to relax and enjoy the other stylish advantages of the A8 L Security even more: perfect driving features and unequalled luxurious comfort. There's no more integral way to experience a special protection vehicle.

---

A close-up photograph of a shattered windshield. The glass is cracked and broken into many small pieces, with some larger fragments visible. A red horizontal bar is overlaid on the left side of the image, containing the number 34. The background is dark and out of focus.

**34**

**35**

**36**

The number issued by the Firing Proof House on the windscreen of the tested A8 L Security.

A black and white photograph of the rear side of an Audi A8 L Security sedan in a modern, minimalist interior. The car is positioned on the right side of the frame, showing its rear wheel, door, and trunk. The background features a large, light-colored wall with a dark baseboard and a ceiling with recessed lighting. A red vertical bar is on the left side of the image, and a red horizontal bar is at the top. The floor is light-colored with a dark line and a square vent. The car's reflection is visible on the floor.

Elegant. Superior. Sporty. The Audi A8 L Security is convincing right from the very first thanks to its striking contours and the harmonious proportions of its long silhouette.





## From now on, security is measured in millimetres.

The series-standard outer shell of the Audi A8 L Security perfectly conceals a network of highly efficient protective components. The combination of first-class design, progressive technology and stylish comfort is setting a standard of its very own. Just like the overall length, which at 5.27 metres ensures a representative appearance, provides a generous amount of legroom in the rear passenger compartment and makes it the longest high-security vehicle in its class.

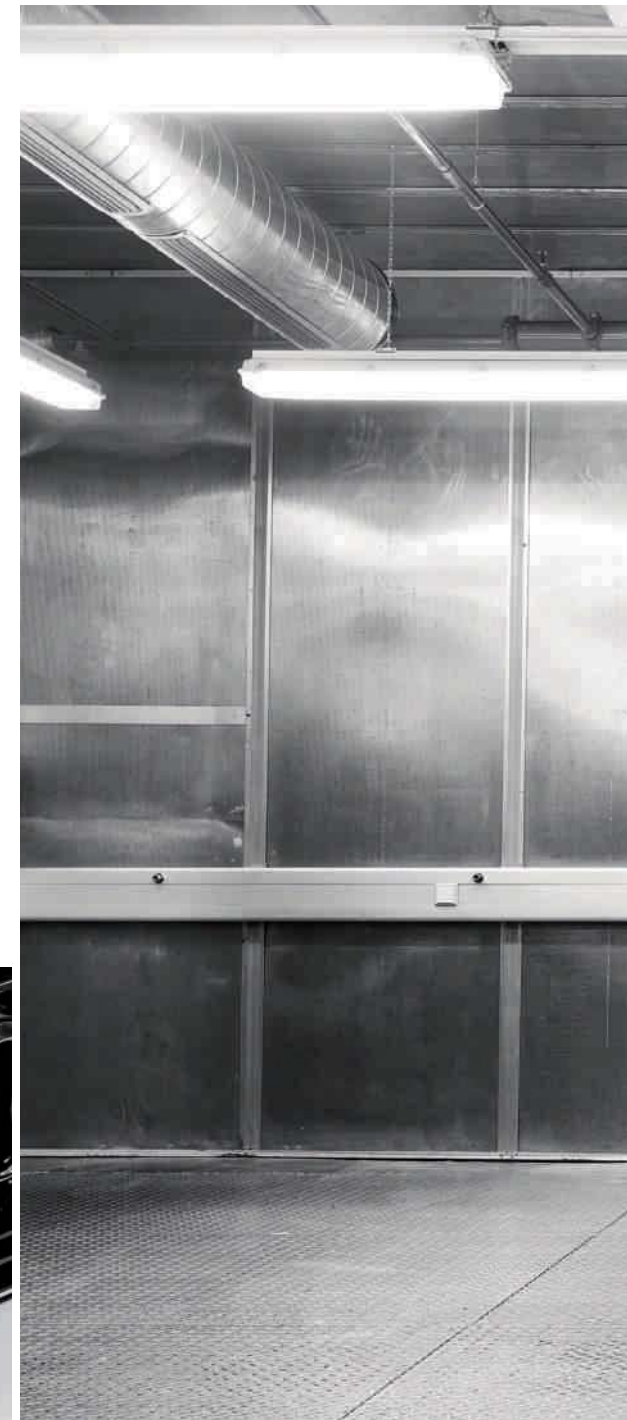



## Unlimited space for your decisions.

The rear passenger compartment is an extremely stylish and roomy environment that allows you to use your valuable time efficiently. Or just to relax. The comprehensive Executive Seating Package can be ordered for top-level entertainment and convenience. You can choose from numerous entertainment settings using the MMI® control panel in the end-to-end, leather-covered central console. As well as regulate the extremely efficient 4-zone deluxe automatic air conditioner. All you need to do is lean back and savour the moments of peace and quiet with a drink from the optional cool box.





The already roomy rear passenger compartment can be made even bigger. In the optional relaxation seat, you can fold the front-passenger seat forward and electrically extend its footrest to achieve a generous resting position for maximum relaxation. Twelve electrical adjustment possibilities, a massage function with four programmes and a comfort head restraint leave nothing to be desired. Particularly convenient: a memory function stores all the settings. The folding table in the centre console puts the finishing touch to the high-quality interior.

Part of the optional Executive Seating Package is the Rear Seat Entertainment with unparalleled advantages. Two high-resolution 10.2 inch LCD displays that can be tilted are integrated in the backs of the front seats. Various different video and audio sources can be controlled and used with these. And two wireless Bluetooth headsets ensure the same intensive listening pleasure as with the standard BOSE surround sound system – without disturbing the rest of the passengers.

Other standard equipment includes a WLAN hotspot and a Bluetooth car phone online. There is a phone with cord available as an option for unlimited phone conversations. An ioniser can be switched on to increase occupant comfort by improving breathable air on the interior, particularly in regions with poor air quality.







It goes without saying that the Audi A8 L Security does justice to the highest of expectations in the cockpit, too, as can be seen by the fine leathers, selected woods and careful workmanship used. There are almost no restrictions placed on your personal wishes. Individual requirements can even be met in terms of safety features. For example, the windscreen and areas of the front side windows can be heated if required, ensuring better visibility when temperatures drop below freezing. Whatever you're intending to do with the A8 L Security: your personal design will keep you safely ahead of the rest.













# The best kind of danger prevention is the kind you can't see.

This is the reason the Audi A8 L Security looks almost no different from the standard A8 L model despite comprehensive special protection features. It allows no conclusions to be drawn about the occupants, which in itself is an additional safety factor. The sporty design manages to do the almost impossible: it attracts everybody's attention yet preserves discretion at the same time. Because what the eye doesn't see is a completely armour-plated protective compartment made of high-strength steel, aramide, ceramics, multi-layer glass and a special aluminium alloy.





Each individual production step is precisely documented and countersigned by the respective employee.

This means the entire production chain is completely documented – providing exemplary transparency and the best basis for your trust.



## Something that deserves our special attention: every tiny detail.

The Audi A8 L Security is manufactured in a separate high-security production facility. This is the only way all the components and production steps can be coordinated precisely for comprehensive security from a single source. During the complex process which can take up to six months of concentrated attention to detail, manual production and state-of-the-art series production are closely interlinked. Synergies are used in the best possible way to guarantee the highest quality standards. After all, every vehicle is one of a kind. And just as unique as its owner.

- 1** Screws are tightened with a specific torque and checked after a certain time.
- 2** Specially calibrated gauge heads check the dimensional accuracy of the body.
- 3** The Audi Space Frame (ASF) is checked by hand.
- 4** High-precision sensors scan it one more time.
- 5** The armoured plating on the underbody is also fitted by hand.

## Maximum protection. Right from the outset.

For the Audi development engineers, security begins with the performance specifications, which integrates all the special protection-specific requirements right from the very beginning. The measures are developed from the drawing board and specially constructed. Not installed afterwards. This custom-fit holistic security concept from the factory offers you several superior advantages:

Suspension and braking system are designed to match the increased requirements either through specific adaptation or complete new developments. The new design of the electronic control systems also means that the higher weight is hardly noticeable. All these factors help the Audi A8 L Security to achieve a comparably high level of driving performance, dynamics and comfort.

The armour-plating is overlapped at all transition spots on the bodyshell. This makes particularly demanding zones such as door and body gaps as well as door locks significantly safer.

However, safety doesn't only mean guaranteeing the best possible protection from terrorist attacks, it also means providing protection in the event of an accident. For this reason, the A8 L Security is subjected to numerous crash tests as well as crash simulation for all components. In addition, the airbag control is completely adapted.





From the outside a door. From the inside – a highly complex protective mechanism made of a wide range of different materials.



## Quality is not a question of exclusivity. It's a question of necessity.

In an emergency, quality can prove a deciding safety factor for vehicle occupants. This is why Audi development engineers are permanently investigating the use of new materials and production methods. The comprehensive use of aluminium and ceramics, for example, allowed a significant weight reduction – at the same time improving resistance to explosives. This has resulted in production of the longest and lightest special protective vehicle of its class – despite the quattro® all-wheel drive. Continuous optimisation of production and numerous testing measures that are carried out during the manufacturing process mean that the claim “Progress in Security” is fulfilled completely – and can be experienced in top-level comfort.

- 1 The evenness of the paint coating is checked in the light tunnel.
- 2 The function of the Audi Space Frame (ASF) is checked in a separate room.
- 3 Measuring robots with contactless optical sensors check component gap widths and flushness.





**1 Armoured sill**

Effective sill reinforcements in the bodyshell for increased protection particularly in the event of an explosion.

**2 Armoured door and side window**

Effective defence against projectiles and glass splinters thanks to special multilayer glass with a polycarbonate layer on the inside. Optional electromechanical side windows can be opened almost completely for nearly unlimited comfort. An electrical door-closing aid ensures safe and elegant closing of the rear doors. And the doorstop function keeps the door open in any required position.

**3 PAX emergency driving system**

The car can go on driving – at a speed of up to 80 km/h – even when a tyre is damaged. The tyre pressure monitoring system permanently monitors tyre pressure during the journey and issues a warning even if there is only a minimal change. This allows the driver to react in good time.

**4 Armoured underbody**

The use of a special aluminium alloy allows a significant weight saving. The special material properties lead to increased protection against explosives. Completely anti-magnetic armouring to prevent the use of limpet mines.

**Emergency fresh air system\***

An air quality sensor permanently monitors the air outside the vehicle and automatically closes the fresh air flaps if an increased level of pollutant or irritant gas is measured, for example. Following manual triggering, the system supplies the occupants with fresh breathable air for a limited period. The resulting excess pressure inside the vehicle prevents the penetration of toxic gases.

**Intercom system**

The powerful microphones and loudspeakers allow communication with people outside the vehicle even with the windows closed.

**Emergency alarm system\***

Can be triggered manually in a hazardous situation. A siren is sounded, the hazard warning lights are activated and headlights dazzle by means of an intermittent main beam.

\*Optional equipment.

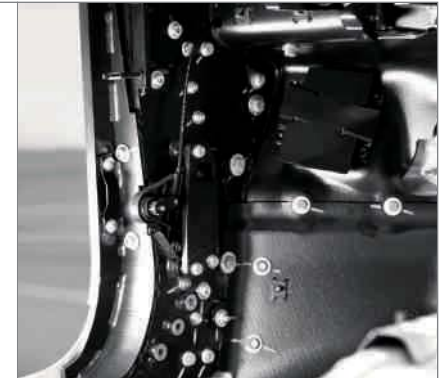

### 353 screw attachment points for a perfect fit.

**The combination of the aluminium of the Audi Space Frame (ASF) with the armouring steel is a magnificent technological achievement.**

The two materials are put together using 353 screw attachment spots without any direct contact to one another. Every single screw is checked by hand and readjusted if necessary. During the shaping of the ballistic steel, a precise temperature-controlled hardness level for each individual piece of steel guarantees high accuracy of fit.

Subject of Audi Space Frame (ASF)

Materials

# There is always a way out. This one is particularly convenient.

The patented and unique emergency exit system provides an intuitive possibility of escape through all four doors. If the doors can no longer be opened normally in an emergency, the doors and the body can be disconnected by means of a pyrotechnic system. The straightforward operability ensure that everyone can leave the Audi A8 L Security quickly and with no great effort in an emergency.

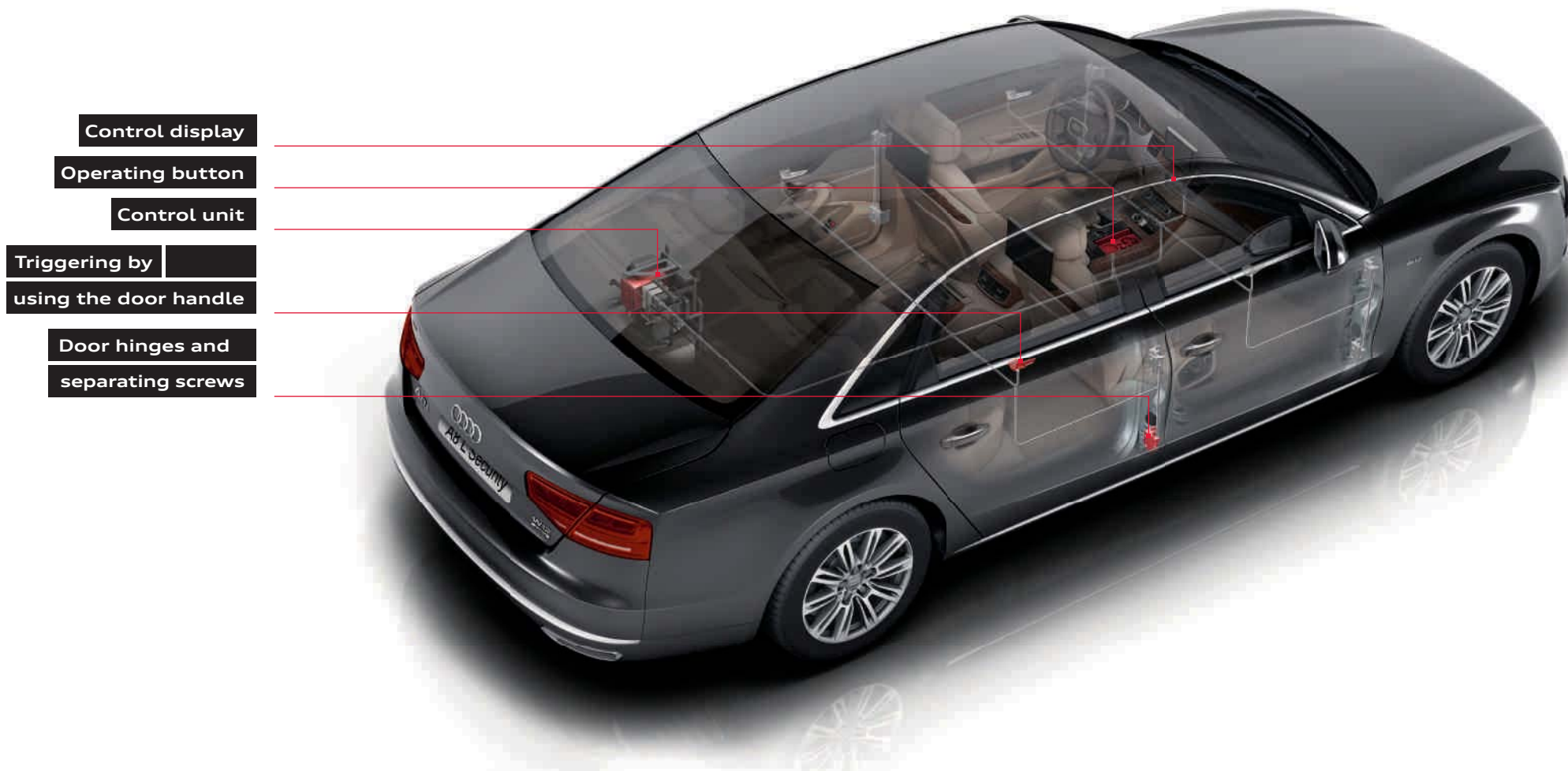

### 1 Rotating beacon\*

Is thief-proof and can be mounted quickly and easily if required. Installation and operation only with official authorisation.

### 2 LED flashing lights\*

The LED flashing lights in the exterior mirrors are activated at the push of a button. Available in combination with the rotating beacon.

### Fuel tank\*

Sheathed with a self-sealing special material that triggers self-sealing in the event of shooting. Special fuel tank and battery armoring is available on request.

\* Optional equipment.



### 3 Fire-extinguishing system\*

Nozzles in the engine compartment, on the underbody and fuel tank and in the wheel housings spray a highly effective extinguishing agent in the event of unusual heat development. The extinguishing system is triggered by temperature sensors or manually via a button in the centre console.

### 4 PAX spare wheel\*

Integrated in the bottom of the luggage compartment without restricting the luggage compartment volume. The lightweight aluminium design guarantees optimised weight and straightforward handling.

### 5 LED display for driving in convoys\*

LED display for the ideal synchronisation of leading and accompanying vehicles in a convoy. Green and yellow LED lights indicate acceleration and deceleration to the driver of the following vehicle.

### 6 Armoured communication box

Integrated in the luggage compartment, it provides secure housing for the important parts of the vehicle electronics, communication equipment and additional optional devices.









## To prevent the emergency being a test run.

Weapon technologies are being further developed all the time. For the Audi experts, this makes the continual development of new materials just as necessary as their consistent testing. First, all the materials used are tested and certified on secluded ground. Then the tests take aim at a complete vehicle, which has shots fired at it from a whole range of weapons from all angles.

The result: The Audi A8 L Security achieves resistance class VR7 (according to BRV 2009) in all vehicle areas. This has been certified by a state Firing Proof House. The areas armoured with steel and ceramics even meet the requirements of firing classes 9 and 10.

But even that is not enough for an Audi special protection vehicle: national security authorities carry out further tests. The vehicle's resistance to automatic weapons and sniper rifles is also tested.

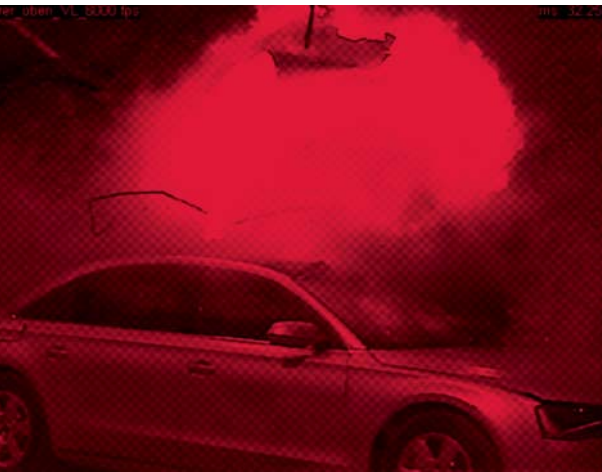

Constantly changing types of terrorist attack compel explosives experts to carry out comprehensive tests – with successful results. Within the context of certification, roof and underbody were tested against the hand grenade HG 85 and found to be safe (in accordance with ERV 2010). National security authorities carried out further explosives tests that went far beyond the defined certification scopes. The armour-plated passenger cell of the Audi A8 L Security withstood these too.

Dummies are used during the explosives tests to measure the effects on the human body. There are up to four dummies sitting in the vehicle. Acceleration in all directions of movement is measured at around 50 measuring spots. An air pressure measuring device recognises the hazard potential for passengers' hearing and lungs. Audi achieves excellent results in these tests too: all values measured prove the high protective effect of the armour-plating for occupants of the vehicle during these explosives tests.



Dragunov sniper rifle

VR10/7.62 x 54R HCI



G36 assault rifle

VR07/5.56 x 45 SCP



AK-47 assault rifle

VR08/7.62 x 39 HCI



G3 assault rifle

VR09/7.62 x 51 HC



Hand grenade HG 85 (CH)





## Drive is the best form of defence.

The best way to avert a dangerous situation is to escape as quickly as possible. Unlimited mobility can thus become a decisive safety factor, which is why the Audi A8 L Security has particularly powerful engines and a superior drive system.



### 1 quattro®/ESP/suspension

During normal driving, the quattro® permanent all-wheel drive distributes the drive power in a 40:60 ratio to all 4 wheels, with most power going to the rear, and avoids wheel spin to a major extent. This means the Audi A8 L Security can prove its superior dynamic potential even in critical driving situations such as swerving manoeuvres or on slippery surfaces. And even on winding roads or in hilly country, quattro gives drivers a better feeling for the road – and increases safety. The exceptional grip is supported by the Electronic Stabilization Programme ESP. Whenever there is a tendency to oversteer or understeer, controlled brake intervention keeps the dynamics out of the critical range.

Important areas of the suspension and braking system were redeveloped for the A8 L Security or adapted to cope with the vehicle weight. These are marked red in the illustration.

## 2 W12 FSI engine

With 368 kW and a maximum torque of 625 Nm, the twelve-cylinder engine guarantees extraordinary driving comfort coupled with outstanding power delivery.

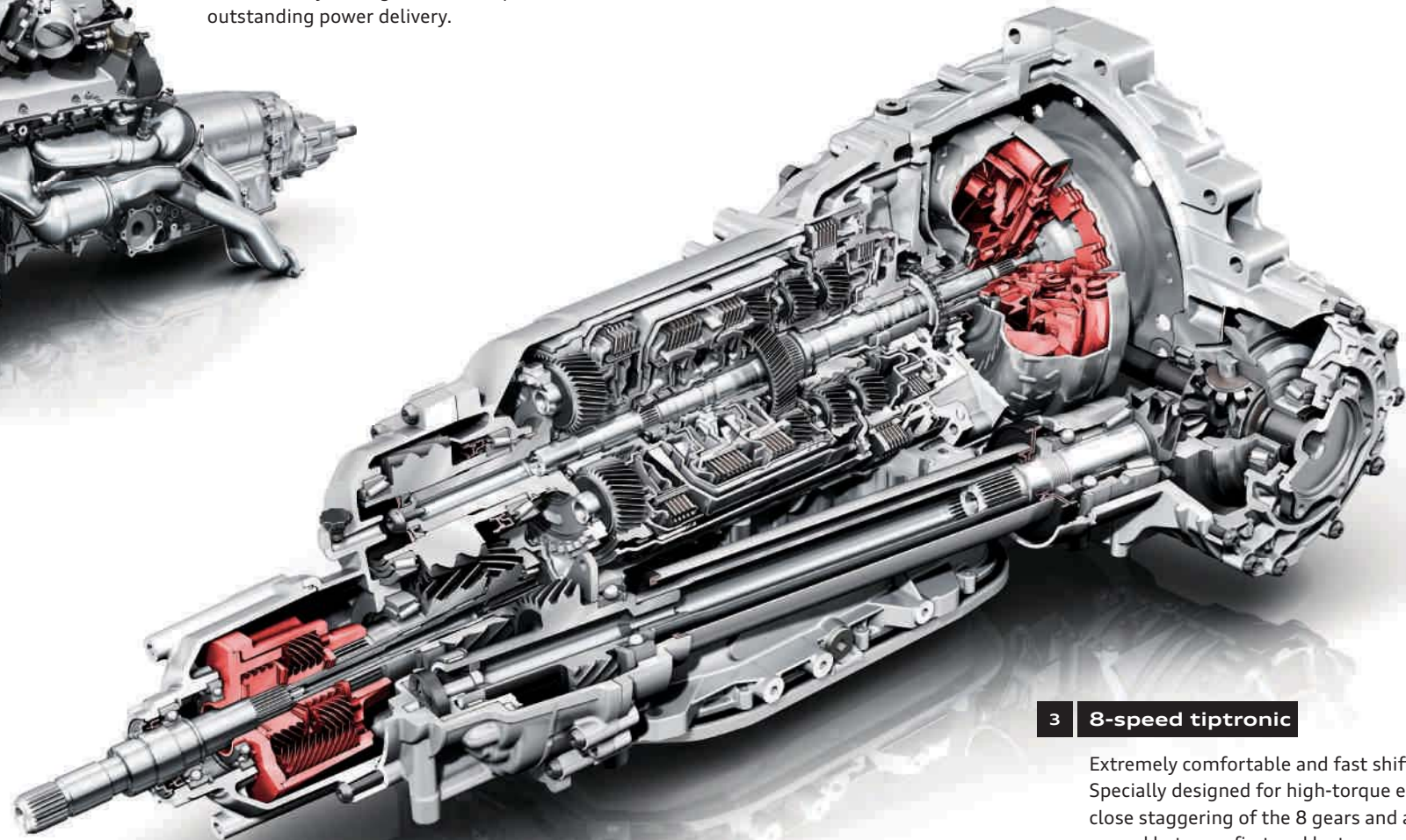
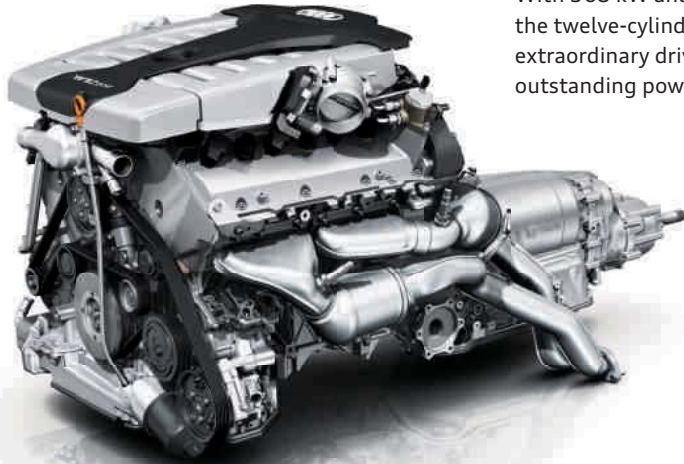

## 3 8-speed tiptronic

Extremely comfortable and fast shifting. Specially designed for high-torque engines. The close staggering of the 8 gears and a large overall spread between first and last gear provide comparatively high efficiency. When the vehicle is accelerated quickly, it skips several gears for unusually fast mobility.

## Systematic safety.

As well as components protecting the vehicle and its occupants against terrorist attacks, the safety concept of the Audi A8 L Security also includes anticipatory driver assistance systems designed to help you avoid accidents to a major extent. At the same time, driver assistance systems help your driver keep an eye on the area around your A8 L Security and thus to identify potential hazards the moment they approach the vehicle.

**Parking system with surround cameras:** the camera system maps the area around the vehicle, at the side and behind from a bird's eye view. The corner-view function provides additional high safety comfort in exit situations where there is only a poor view by providing an early overview of approaching vehicles or people. An optional camera at the rear for observation purposes and long-range control of following vehicles can also be installed in addition to the camera system.



**Night vision assistant:**  
With the aid of a thermo-imaging camera, the optional night vision assistant highlights people detected at a distance of about 15 to 90 metres in front of the vehicle by yellow markings in the driver information system. If the vehicle threatens to collide with the detected pedestrian, the colour changes to red and a warning signal is sounded.

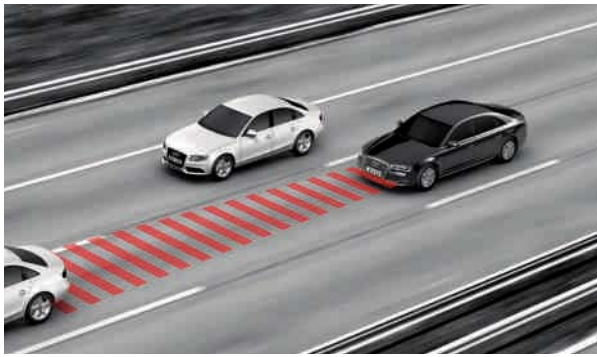

#### **adaptive cruise control with**

#### **Stop&Go function including**

#### **Audi pre sense front**

On clear roads, the optional system maintains a chosen speed within the range of 0 to 210 km/h and keeps the correct distance to the vehicle in front. In slow-moving traffic or in a traffic jam it regulates slowing down, starting up and crawling through traffic. If an obstacle is detected, the driver is alerted by an acoustic signal and a display on the driver information system.

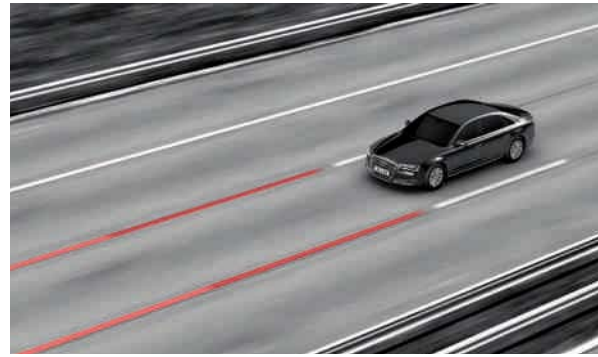

#### **Audi lane assist**

If required, the system helps the driver to keep in lane, thus avoiding accidents. If the Audi A8 L Security threatens to drift out of lane, the driver is warned by steering wheel vibrations. Audi lane assist does not actively intervene in the driving situation.

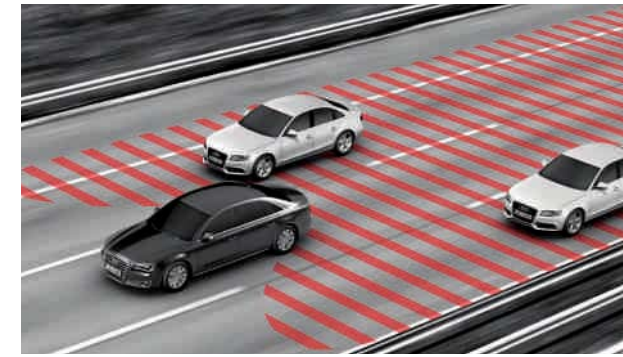

#### **Audi side assist including**

#### **Audi pre sense rear**

From a speed of 30 km/h, the area alongside and behind your vehicle is observed by radar sensors. If there is a vehicle in this area, the driver is warned by the LED display near the exterior mirror lighting up permanently. If the driver sets the indicator in this situation, the system warns of a possible collision via a signal. Audi side assist does not intervene in vehicle steering and can be deactivated at any time by the driver pressing a button in the driver door. Audi pre sense rear uses rear sensors to detect traffic behind the vehicle and in addition to the preventative occupant protection systems of the Audi pre sense basic system (tightening of the front safety belts, activation of the hazard warning lights in critical driving situations), it also moves the standard memory seats into a position favourable for a rear-end collision. If available, the pneumatic side bolsters are filled to improve occupants' stability.



## Subject of Service

## Driver training and hotline

**All-round support from the Audi safety experts: Audi Security Training and Audi Security Service.**

During a journey in the Audi A8 L Security, you decide on direction and destination. But it is your driver, with his driving knowledge and experience who decides what will happen in a critical situation. During special training sessions the participants learn how to handle the A8 L Security in an anticipatory and superior way under different circumstances and on different grounds.

Safe and fast help are guaranteed by the unique Audi Security Service. Special security-specific service technicians are employed at 38 centres around the world – 14 of these in Germany. Many of them are manned round the clock: the Audi Security Service hotline is staffed 24 hours a day, 365 days a year. Further technicians are on call to help solve problems as quickly as possible, and can drive from the parent plant to one of the service centres or directly to you without delay.









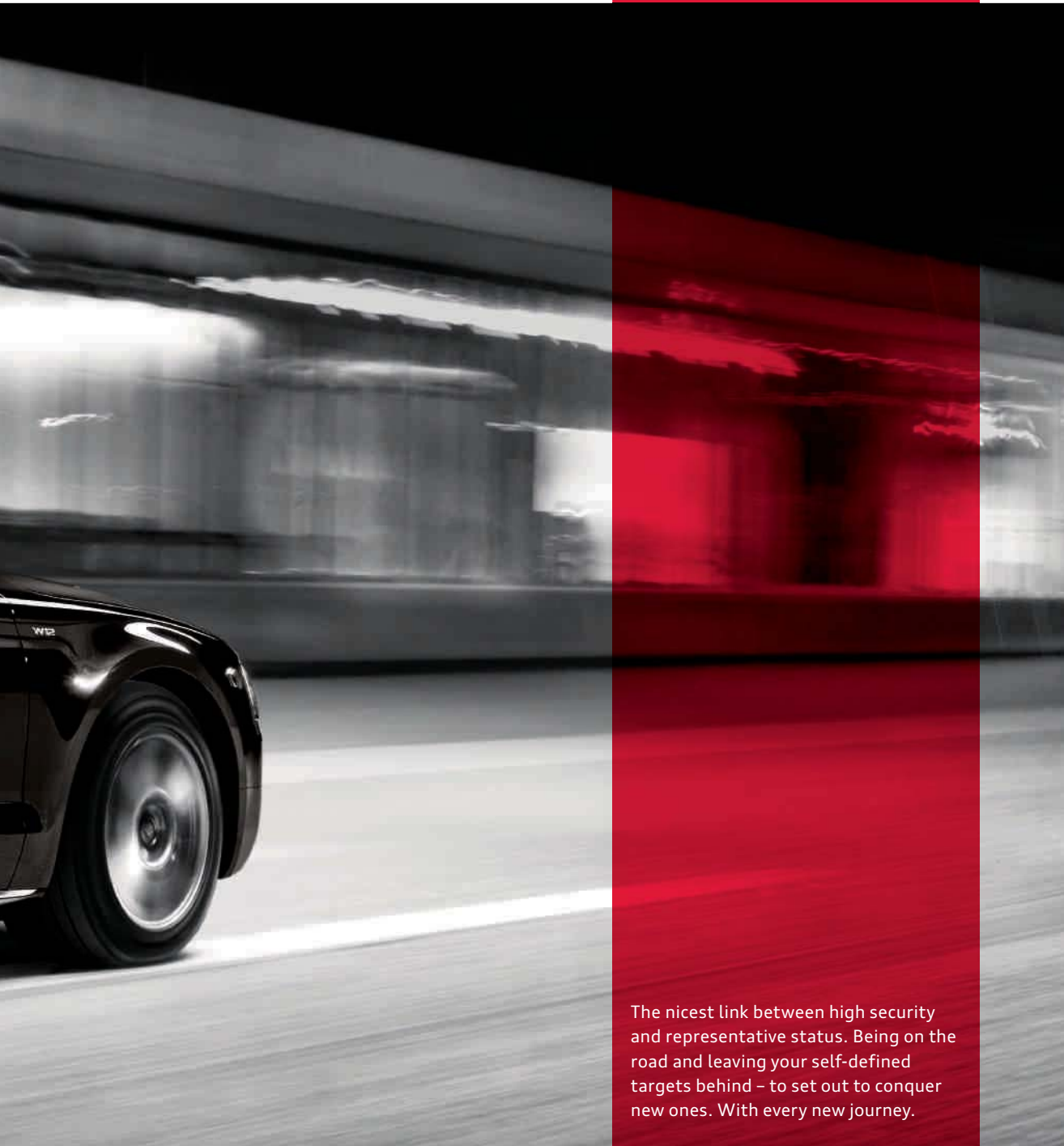

The nicest link between high security and representative status. Being on the road and leaving your self-defined targets behind – to set out to conquer new ones. With every new journey.

	A8 L Security twelve-cylinder
<b>Special protection</b>	
<b>Specially protected passenger cell</b> according to bulletproof class VR7 (certified to BRV 2009), important vehicle elements and the optional communication electronics as well as the second battery and further additional devices in the protected area are housed here, armoured glazing with polycarbonate coating, additional protective effect against hand grenades (HG 85) on the underbody and roof and side panels tested for explosives-resistance	<input type="checkbox"/>
<b>Body Audi Space Frame (ASF)</b> (ASF)-construction, reinforced, with integrated armour-plating	<input type="checkbox"/>
<b>Reinforced armour-plating on the underbody</b> weight-saving design	<input type="checkbox"/>
<b>Intercom system</b> for safe communication between people outside the vehicle and passengers on the inside	<input type="checkbox"/>
<b>Fire-extinguishing system</b> triggered by sensors in the engine compartment, on the underbody or tank, or manually	<input checked="" type="checkbox"/>
<b>Emergency alarm system</b> to attract attention in an emergency by means of intermittent flashing of the main beam, flashing of all indicators and sounding of the siren in a special key. Can be triggered manually	<input checked="" type="checkbox"/>
<b>Rear camera</b> in addition to the standard parking assistant systems, for monitoring the area behind the vehicle	<input checked="" type="checkbox"/>
<b>Emergency exit system</b> exit through the door in an emergency, pyrotechnic separation of the door hinges, for all doors, simple, fast and reliable operation from the passenger compartment, intuitive escape route	<input checked="" type="checkbox"/>
<b>Safety starting system</b> allows the engine to be started from a safe distance	<input checked="" type="checkbox"/>
<b>Rotating beacon</b> with tone sequence, can be removed and locked, with quick-action lock for safe roof-mounting	<input checked="" type="checkbox"/>
<b>LED flashing lights</b> in the exterior mirrors (can only be ordered in conjunction with the rotating beacon)	<input checked="" type="checkbox"/>
<b>Signalling system for driving in convoys</b> using LED technology	<input checked="" type="checkbox"/>
<b>Pennant holder</b> left and/or right	<input checked="" type="checkbox"/>
<b>Fuel tank with self-sealing special coating</b>	<input checked="" type="checkbox"/>

	A8 L Security twelve-cylinder
<b>Armouring for fuel tank and battery</b>	<input checked="" type="checkbox"/>
<b>Accident data recorder</b>	<input checked="" type="checkbox"/>
<b>Double rear-view mirror</b>	<input checked="" type="checkbox"/>
<b>Wheels/tyres</b>	
<b>Forged aluminium wheels, 10-parallel-spoke design</b> part-polished, 2-colour, size 9 J x 19 with 255/720 R 490 117 H tyres (PAX)	<input type="checkbox"/>
<b>Wheel bolts, anti-theft</b> can only be loosened with the supplied adapter	<input type="checkbox"/>
<b>Tyre pressure monitoring system</b> monitors the set tyre pressures during a journey; tyre pressures and wheel temperatures can be displayed on the MMI display	<input type="checkbox"/>
<b>Spare wheel</b> full-size, stored in a separate compartment under the luggage compartment floor	<input checked="" type="checkbox"/>
<b>5 complete winter wheels</b> forged aluminium wheels, 10-parallel-spoke design, part-polished, 2-colour, size 9 J x 19 with 245/710 R 490 AC 117 T tyres (PAX)	<input checked="" type="checkbox"/>
<b>5 complete winter wheels</b> forged aluminium wheels, 10-parallel-spoke design, part-polished, 2-colour, size 9 J x 19 with 245/710 R 490 AC 117 T tyres (PAX SPIKE)	<input checked="" type="checkbox"/>
<b>Lights</b>	
<b>LED headlights</b>	<input type="checkbox"/>
<b>Ambient lighting</b> additional reading lights and make-up mirror in the rear compartment	<input type="checkbox"/>
<b>Closing systems</b>	
<b>Comfort key</b>	<input type="checkbox"/>
<b>Servo closing</b> for the rear doors and luggage compartment lid	<input type="checkbox"/>
<b>Luggage compartment lid with electric opening and closing function</b>	<input type="checkbox"/>
<b>Anti-theft alarm</b> with tow-away protection	<input type="checkbox"/>

	A8 L Security twelve-cylinder
<b>Glazing</b>	
<b>Sunblinds</b> electrically operated for the rear window and the rear side windows	<input type="checkbox"/>
<b>Dark-tinted windows (privacy glazing)</b>	<input checked="" type="checkbox"/>
<b>Heated windscreen</b> with SGS ICECONTROL® as well as partly heated front side windows	<input checked="" type="checkbox"/>
<b>Seats/leather upholstery and trim</b>	
<b>Comfort seat package, front</b> in Valcona leather	<input type="checkbox"/>
<b>Individual seat package, rear</b> with comfort headrests, rear	<input type="checkbox"/>
<b>Individual seat package, rear</b> with end-to-end leather-covered central console	<input checked="" type="checkbox"/>
<b>Relaxation seat package, rear</b> with end-to-end leather-covered central console	<input checked="" type="checkbox"/>
<b>Full leather package</b>	<input type="checkbox"/>
<b>Headlining and rear parcel shelf</b> in Alcantara	<input type="checkbox"/>
<b>Inlays</b>	
<b>Lower inlay</b> silver brushed aluminium, aluminium look and extended aluminium look on the interior	<input type="checkbox"/>
<b>Upper inlay walnut brown</b>	<input type="checkbox"/>
<b>Upper inlay (further wood types)</b>	<input checked="" type="checkbox"/>
<b>Roof grab handles with wooden segments</b>	<input type="checkbox"/>
<b>Steering wheels</b>	
<b>Leather-covered multifunction steering wheel, 4-spoke design</b> with shift paddles, heated	<input type="checkbox"/>
<b>Climate control</b>	
<b>4-zone deluxe automatic air conditioner</b> with selectable ioniser	<input type="checkbox"/>
<b>Auxiliary heating/ventilation</b>	<input checked="" type="checkbox"/>

	A8 L Security twelve-cylinder
<b>Further interior equipment</b>	
<b>Audi exclusive cool box</b>	<input checked="" type="checkbox"/>
<b>Audi exclusive folding table</b>	<input checked="" type="checkbox"/>
<b>MMI® navigation, radio and TV systems</b>	
<b>MMI® navigation plus with MMI® touch</b> including Audi music interface, single DVD drive and Bluetooth interface	<input type="checkbox"/>
<b>BOSE Surround Sound</b>	<input type="checkbox"/>
<b>TV reception</b>	<input type="checkbox"/>
<b>DVD/CD changer</b>	<input checked="" type="checkbox"/>
<b>Digital Audio Broadcasting reception (DAB)</b>	<input checked="" type="checkbox"/>
<b>Rear Seat Entertainment</b>	<input checked="" type="checkbox"/>
<b>Telephone and communication</b>	
<b>Bluetooth car phone online</b> including handset in the front	<input type="checkbox"/>
<b>Handset for Bluetooth car phone online</b> front and rear	<input checked="" type="checkbox"/>
<b>Permanently installed phone (cord phone)</b> with private mode, with either 1 or 2 handsets	<input checked="" type="checkbox"/>
<b>Fitting for radio network for security authorities</b> concealed and protected installation, either within reach of the driver or in the glove compartment	<input checked="" type="checkbox"/>
<b>Assistance systems</b>	
<b>Audi side assist</b> including Audi pre sense basic and Audi pre sense rear (functional scope specifically for special security version)	<input type="checkbox"/>
<b>Parking system with surrounding cameras</b> representation of corner view at the front and rear, front view and rear view	<input type="checkbox"/>
<b>adaptive cruise control with Stop&amp;Go function</b> including Audi pre sense plus (functional scope specifically for special security version)	<input checked="" type="checkbox"/>
<b>Night vision assistant</b> including marking of pedestrians detected	<input checked="" type="checkbox"/>
<b>Audi lane assist</b>	<input checked="" type="checkbox"/>

	A8 L Security twelve-cylinder
<b>Suspension/brakes</b>	
<b>Audi drive select</b>	<input type="checkbox"/>
<b>adaptive air suspension</b> reinforced, electronically controlled air suspension adapted to the vehicle weight, with continuously adaptive damper system, including ride height control and manual lift function, various modes can be selected via Audi drive select	<input type="checkbox"/>
<b>Reinforced braking system</b> with braking power adapted to the vehicle weight and hydraulic booster failure compensation	<input type="checkbox"/>
<b>Technology/Safety</b>	
<b>quattro®</b> plus electronic differential lock on the front axle for active torque distribution	<input type="checkbox"/>

## Notes

These pages contain a selection of the standard and optional equipment for the Audi A8 L Security. You can find further descriptions of equipment and options in the Audi A8 L W12 product catalogue.

Audi exclusive, a service from quattro GmbH. Paintwork according to your wishes, fine leather, selected woods and decors. We will be happy to receive your special requests.

Customised solutions: Please contact us if you require customised solutions or special security or communication equipment.

Equipment in the Audi A8 L Security shown in the photo:

Paintwork: havana black metallic; wheels: forged aluminium wheels, 10-parallel-spoke design (PAX);

Seats/seat covers: Comfort seats in Valcona leather, velvet beige; inlays: upper inlay fine grain ash velvet brown, lower inlay silver brushed aluminium including extended aluminium look

<b>Model</b>		<b>A8 L Security W12 quattro</b>
Engine type		W12 engine
Displacement in cc (valves per cylinder)		6299 (4)
Max. output <sup>1</sup> in kW at rpm		368/6200
Max. torque in Nm at rpm		625/4750
<b>Power transmission/wheels</b>		
Type of drive		quattro® permanent all-wheel drive
Transmission		tiptronic
Wheels		Forged aluminium wheels, 10-parallel-spoke design, 9 J x 19
Tyres		255/720 R 490 117 H (PAX)
<b>Weights/capacities</b>		
Unladen weight in kg DIN/EU		3650/3725 <sup>2</sup>
Gross vehicle weight in kg		4250
Gross load in kg		600
Fuel tank capacity, approx. in l		90
<b>Performance/consumption<sup>3</sup></b>		
Top speed in km/h		210 <sup>4</sup>
Acceleration 0–100 km/h in s		7.3
Fuel grade		Sulphur-free super unleaded RON 95 <sup>5</sup>
Fuel consumption <sup>6</sup> in l/100 km	urban	19.9
	extra-urban	9.8
	combined	13.5
CO <sub>2</sub> emissions <sup>6</sup> in g/km	urban	464
	extra-urban	228
	combined	314
Emissions standard		EU5

### Explanatory notes

- <sup>1</sup> The figure stated was calculated using the specified measuring procedure (current version of Directive 80/1269/EEC).
- <sup>2</sup> Weight of car, unladen, with driver (68 kg), luggage (7 kg) and with fuel tank filled to 90 %, calculated in accordance with the current version of EC Directive 92/21/EEC. Optional equipment may increase the car's unladen weight and drag coefficient, whereupon the possible payload limit and the top speed will be reduced accordingly.
- <sup>3</sup> A vehicle's fuel consumption and CO<sub>2</sub> emissions do not just depend on how efficiently the vehicle uses the fuel, but are also influenced by driving behaviour and other non-technical factors. CO<sub>2</sub> is the greenhouse gas primarily responsible for global warming.
- <sup>4</sup> Regulated.
- <sup>5</sup> We recommend using sulphur-free super unleaded RON 95 in accordance with DIN EN 228. If not available, use sulphur-free regular unleaded RON 91 in accordance with DIN EN 228; power output will be slightly reduced. Unleaded RON 95 fuel with a maximum ethanol content of 10% (E10) can generally be used. Fuel consumption details refer to operation with RON 95 fuel in accordance with 692/2008/EC.
- <sup>6</sup> The figures given were calculated using the specified measuring procedures. The figures do not refer to one individual vehicle and do not form part of any offer, but rather should be used purely for purposes of comparison between the different vehicle models.

### Important note

Inspections are due as shown by the service display.

Audi A8 L Security

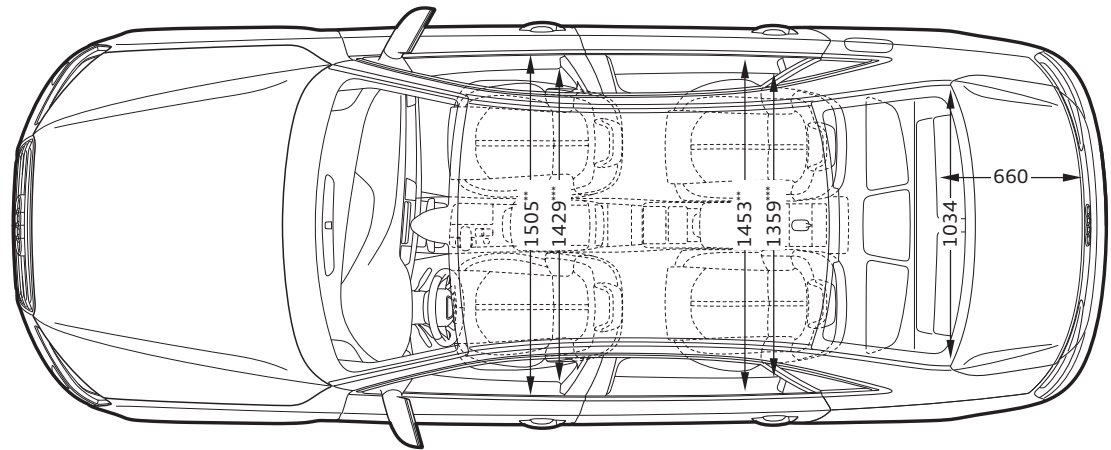
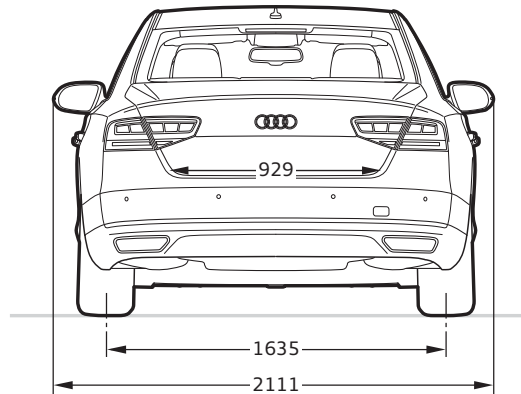
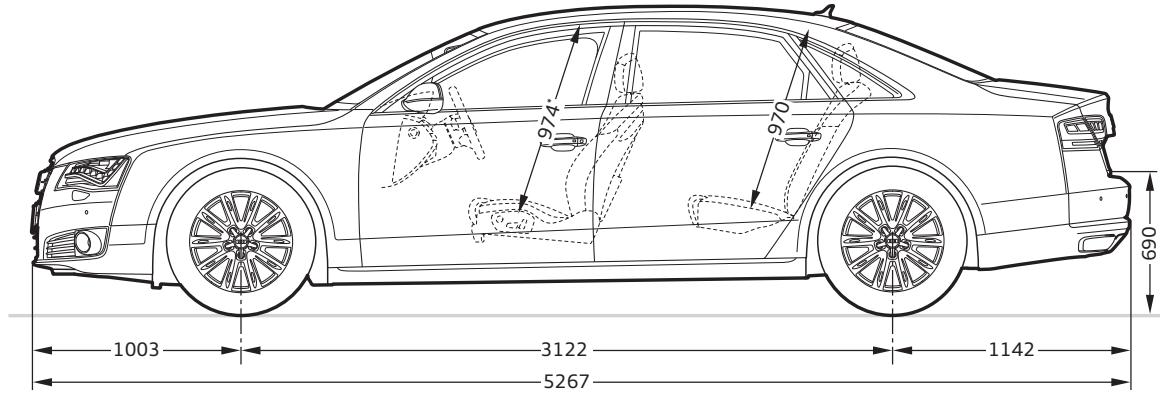
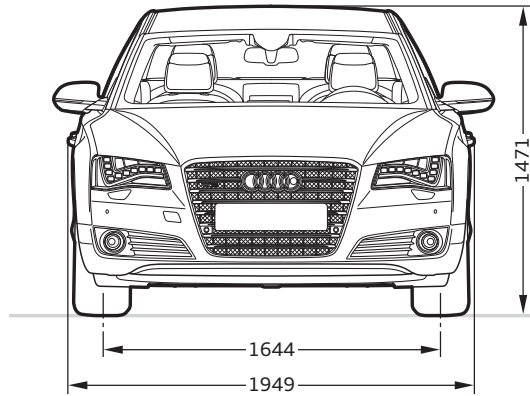

**Dimensions in millimetres.**

Dimensions were measured with vehicle at unladen weight, ground clearance measured with vehicle carrying its maximum load.

Luggage compartment volume 375 l (measured by the VDA method using 200 x 100 x 50 mm blocks).

\*Maximum headroom. \*\*Elbow room width. \*\*\*Shoulder room width.







